

Seitenansicht
von links

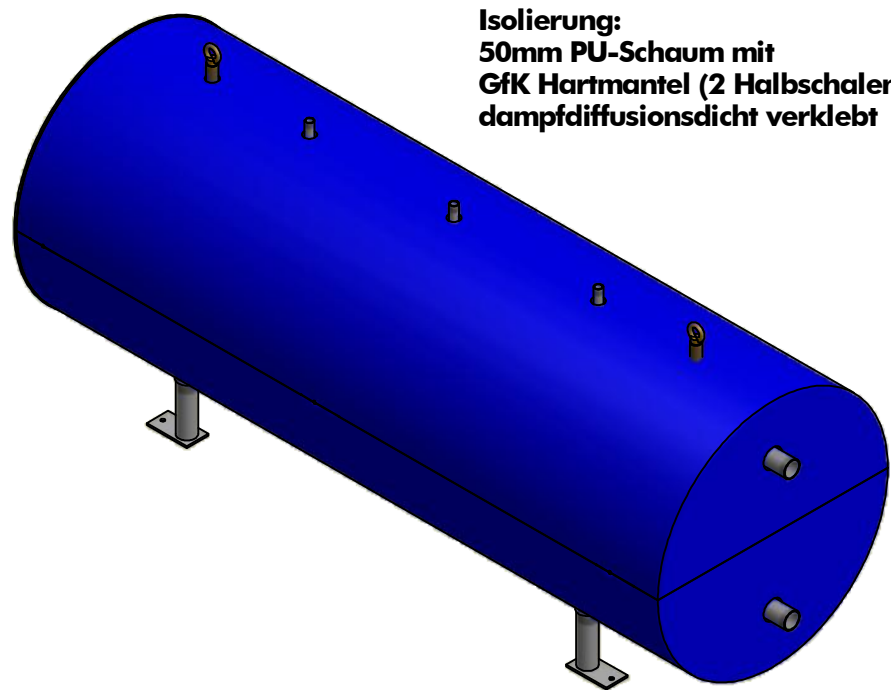
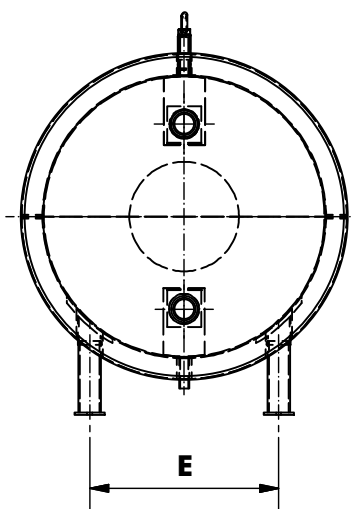

Isolierung:
50mm PU-Schaum mit
GfK Hartmantel (2 Halbschalen)
dampfdiffusionsdicht verklebt

Inhalt	A = Gesamthöhe bei Fußfreiheit 150mm	B = \varnothing Tank	C = \varnothing Isolierung	D = Fußabstand 1	E = Fußabstand 2	F = Mantelschuss Länge	G = Klörperboden Höhe	H = Länge der Isolierung	I = Gesamtlänge Tank	J = Fußgröße	Gewicht
180ltr.	ca. 750mm	500mm	610mm	520mm	340mm	823mm	127mm	1230mm	ca. 1390mm	1 1/4"	95kg
280ltr.	ca. 850mm	600mm	710mm	550mm	400mm	750mm	146mm	1180mm	ca. 1340mm	1 1/4"	110kg
400ltr.	ca. 850mm	600mm	710mm	810mm	400mm	1234mm	146mm	1670mm	ca. 1830mm	1 1/4"	140kg
700ltr.	ca. 1000mm	750mm	860mm	1090mm	500mm	1388mm	180mm	1890mm	ca. 2050mm	2"	220kg
950ltr.	ca. 1000mm	750mm	860mm	1090mm	500mm	1908mm	180mm	2400mm	ca. 2560mm	2"	280kg