

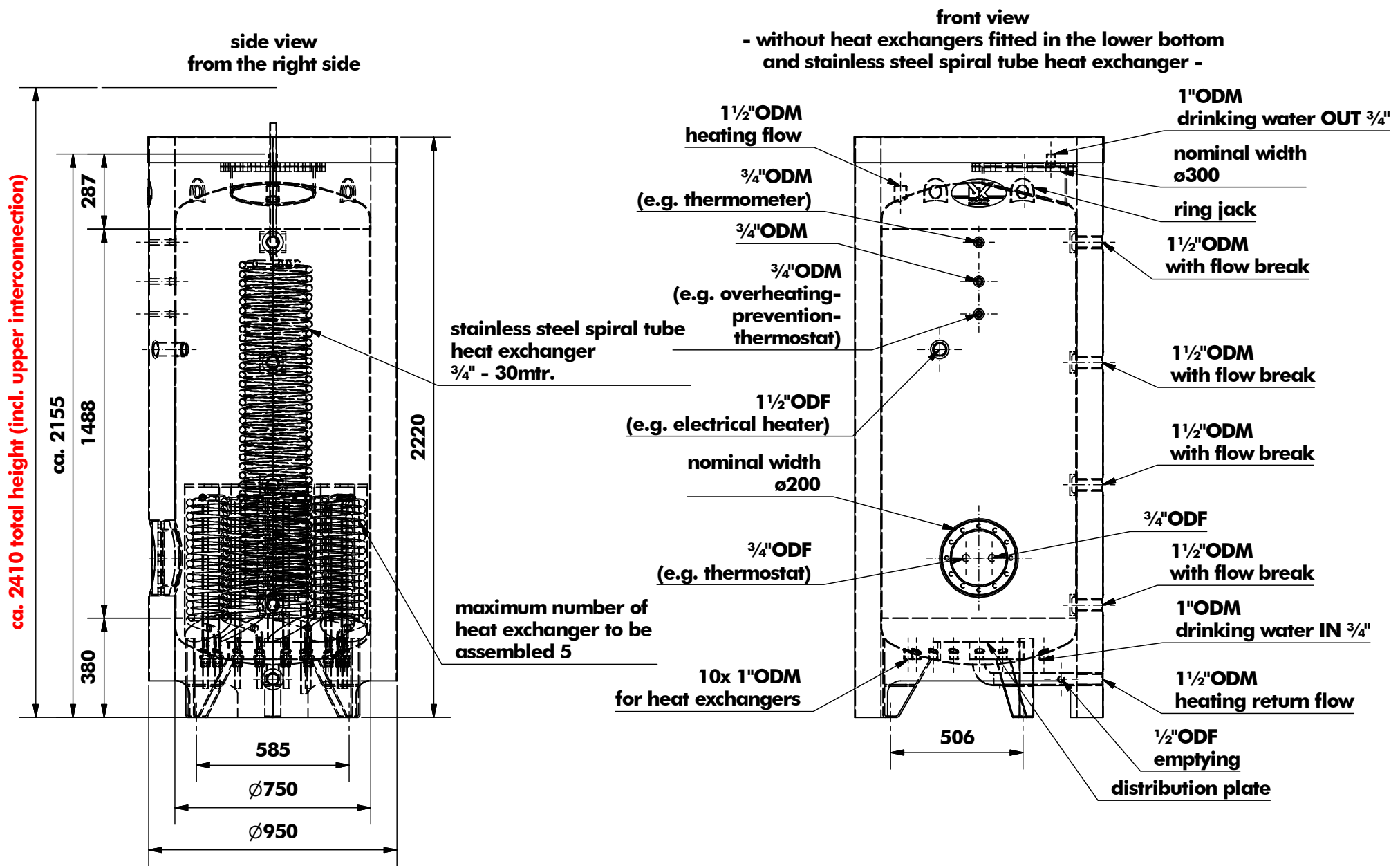

energy storage tank

typ 750 - stainless steel spiral tube heat exchanger 3/4"/30mtr. with heat exchangers fitted in the lower bottom



insulation:
100mm non-woven
incl. polystyrolplate with
completely glued
PVC-covering

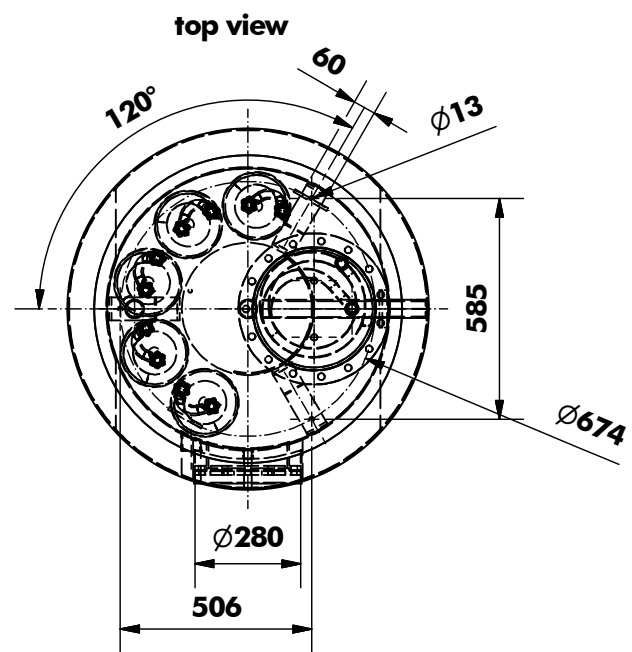
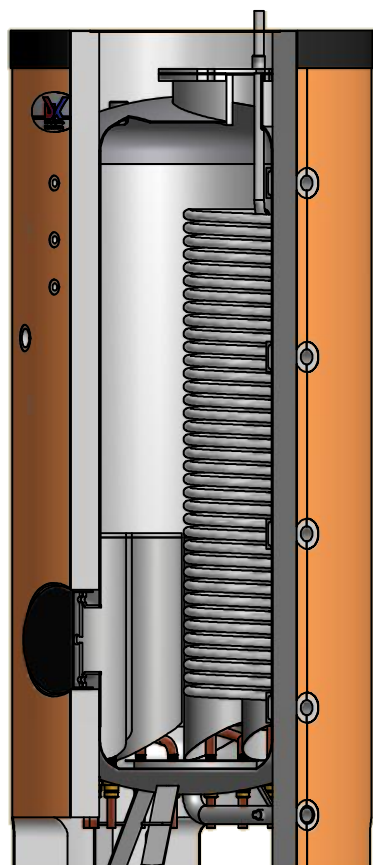

technical data

height of storage tank	2155mm
ø without insulation	750mm
ø with PVC-covering	950mm / 100mm non woven incl. polystyrolplate with completely glued PVC-covering
nominal content	750ltr.
weight whitout the heat exchangers	ca. 230kg
operating pressure	3bar
necessary flange for mounting the stainless steel spiral tube heat exchanger	nominal width ø300
maximum number of heat exchanger to be assembled	5 Stck.
stainless steel spiral tube heat exchanger dimension / length / weight	3/4" / 30mtr. / 8kg