

insulation:  
100mm non-woven  
incl. polystyrolplate with  
completely glued  
PVC-covering

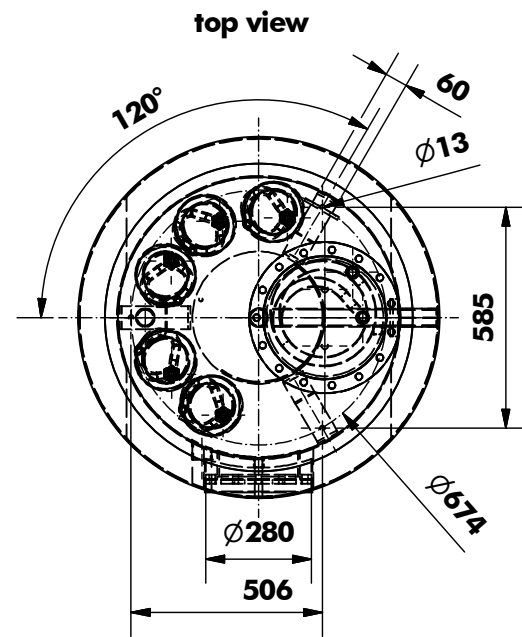
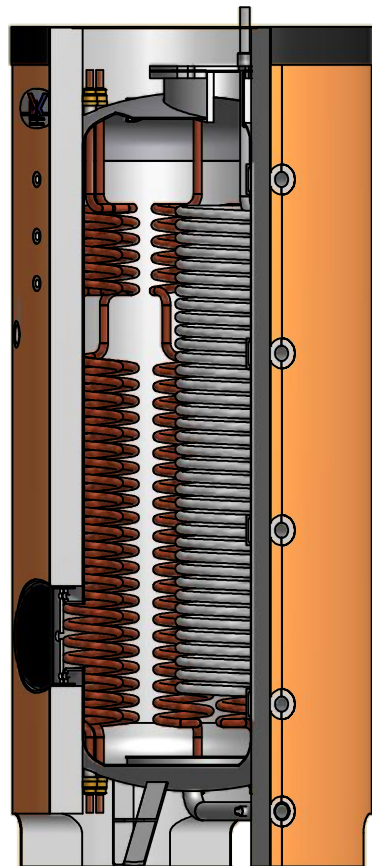

### technical data

height of storage tank	2155mm
$\phi$ without insulation	750mm
$\phi$ with PVC-covering	950mm / 100mm non woven incl. polystyrolplate with completely glued PVC-covering
nominal content	750ltr.
weight whitout the heat exchangers	ca. 230kg
operating pressure	3bar
necessary flange for mounting the stainless steel spiral tube heat exchanger	nominal width $\phi 300$
maximum number of heat exchanger to be assembled	5 Stck.
stainless steel spiral tube heat exchanger dimension / length / weight	$\frac{3}{4}$ " / 30mtr. / 8kg