

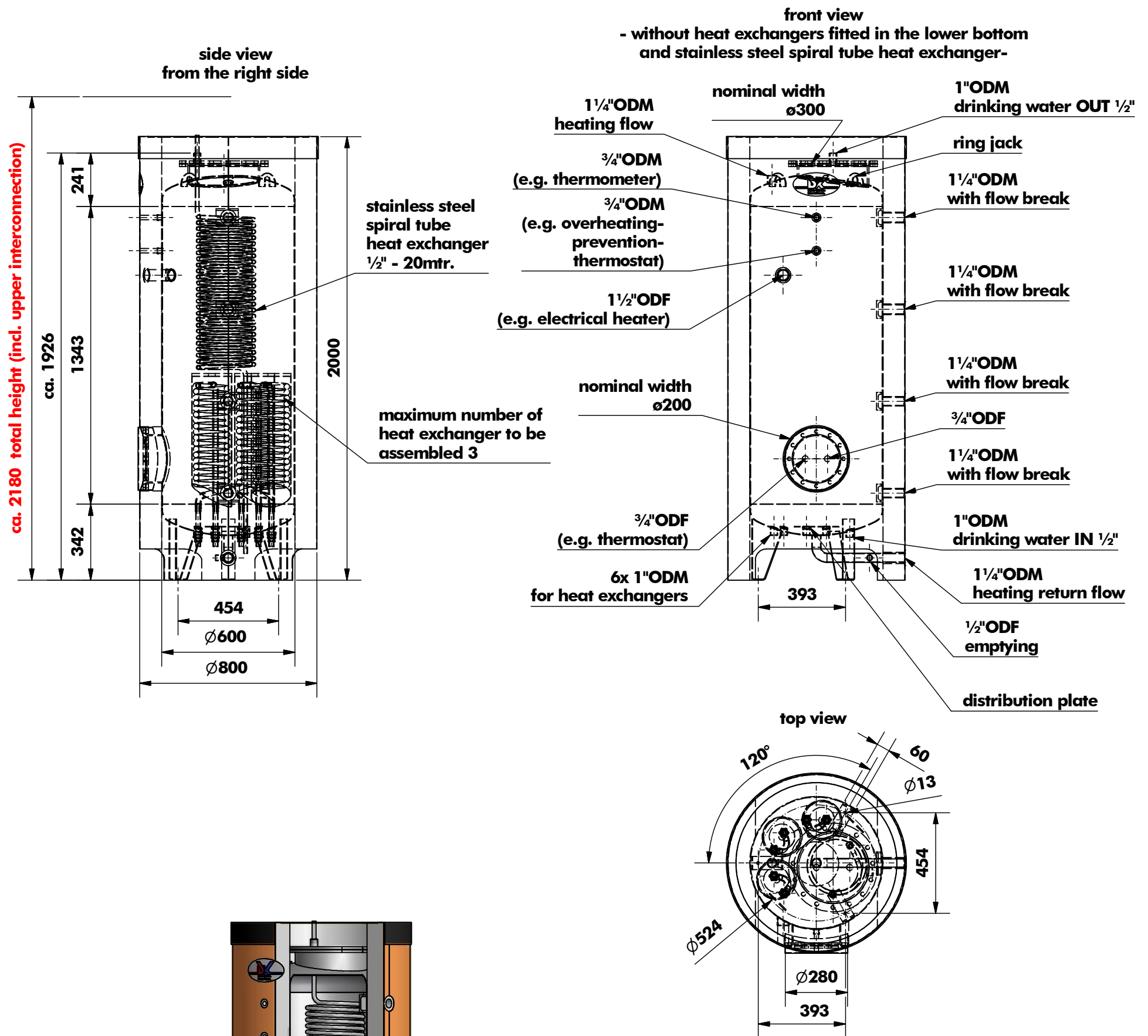

energy storage tank

typ 450 - stainless steel spiral tube heat exchanger 1/2"/20mtr. with heat exchangers fitted in the lower bottom



insulation:
100mm non-woven
incl. polystyrolplate with
completely glued
PVC-covering

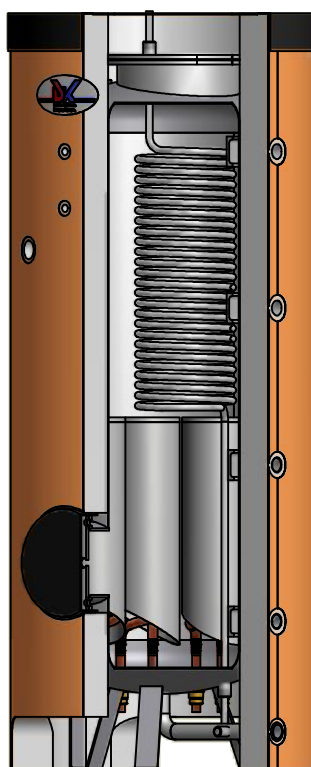

technical data

height of storage tank	1926mm
ø without insulation	600mm
ø with PVC-covering	800mm / 100mm non woven incl. polystyrolplate with completely glued PVC-covering
nominal content	450ltr.
weight whitout the heat exchangers	ca. 150kg
operating pressure	3bar
necessary flange for mounting the stainless steel spiral tube heat exchanger	nominal width ø300
maximum number of heat exchanger to be assembled	3 Stck.
stainless steel spiral tube heat exchanger dimension / length / weight	1/2" / 20mtr. / 4kg