

energy storage tank

typ 1.000/ø800 - stainless steel spiral tube heat exchanger 1"/50mtr. with extendet heat exchangers

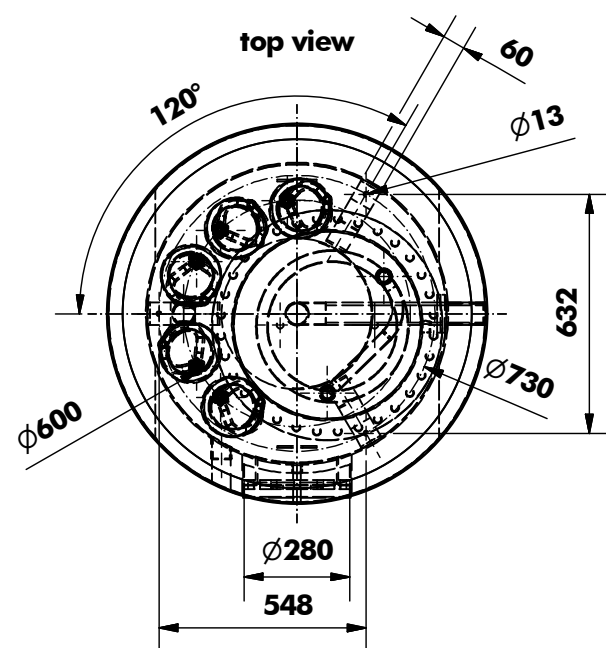

insulation:
100mm non-woven
incl. polystyrolplate with
completely glued
PVC-covering

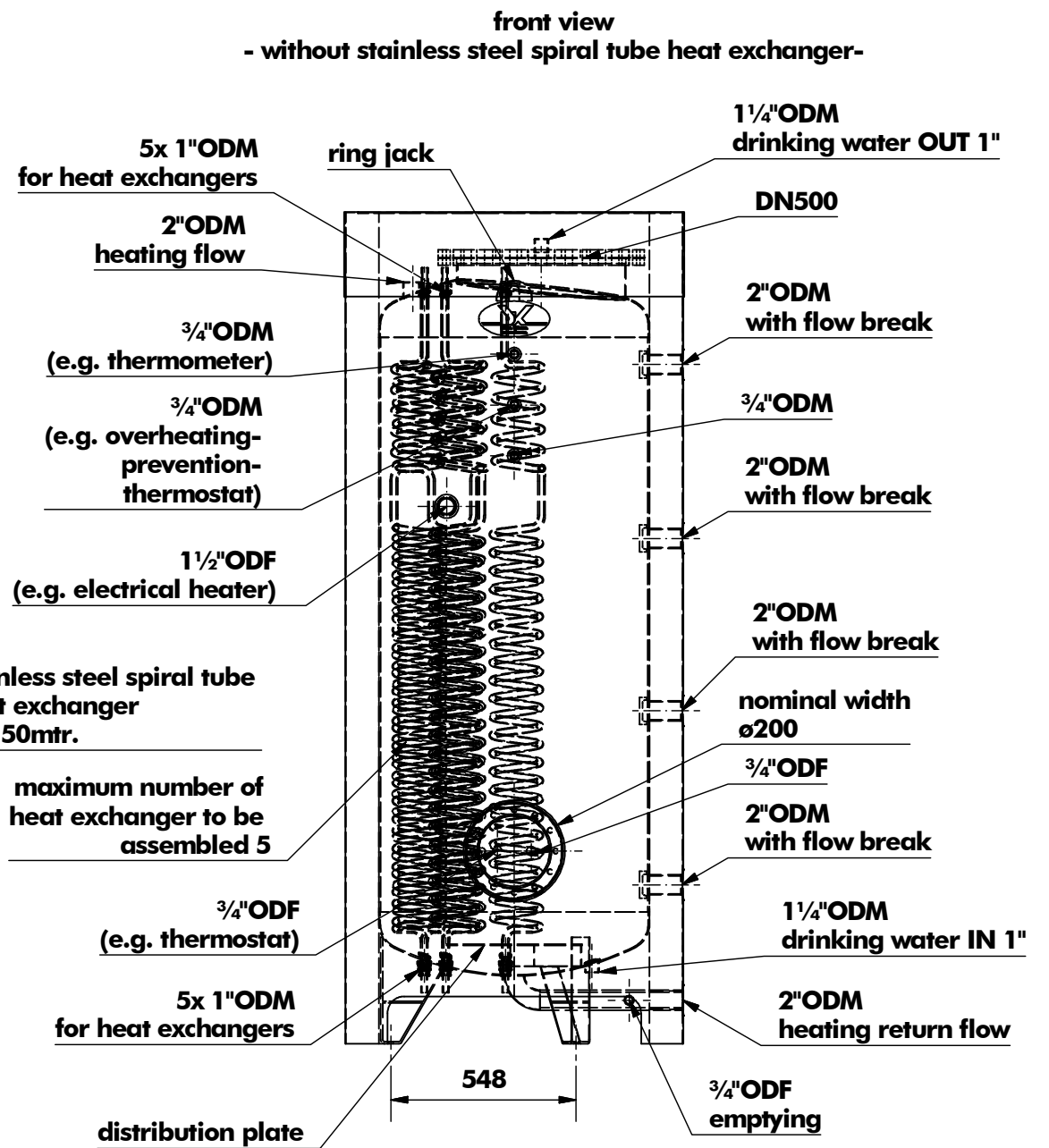
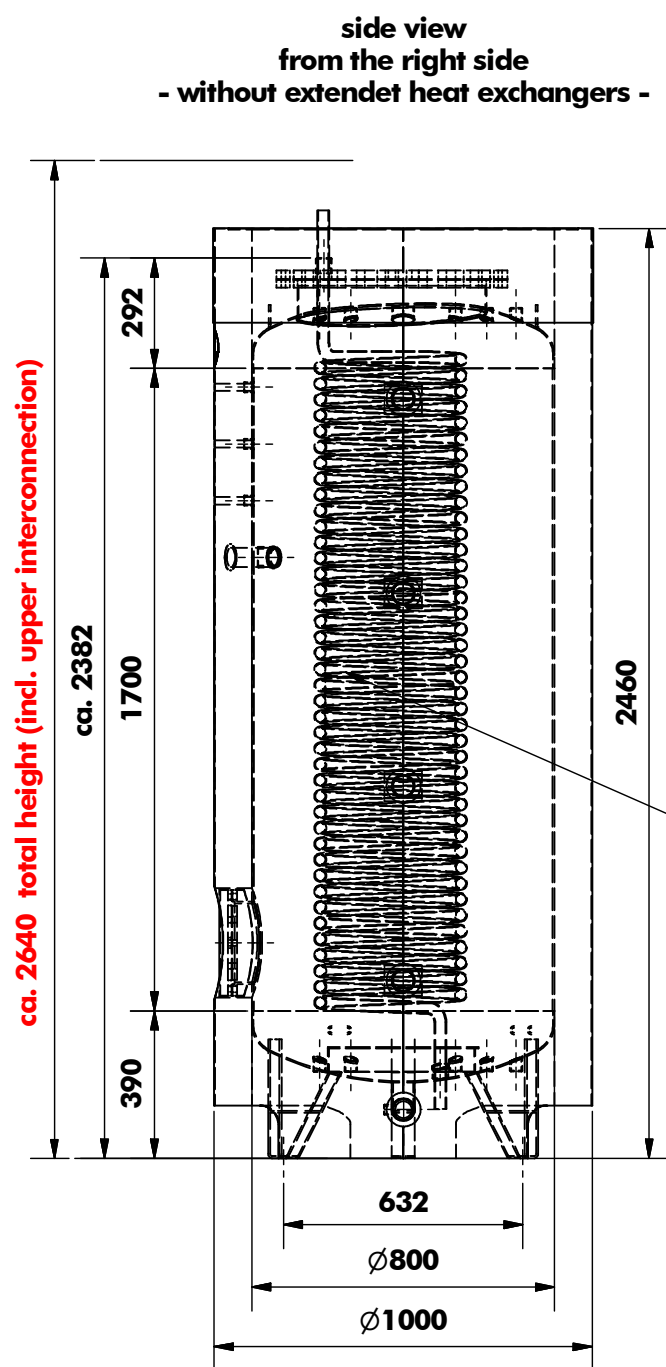
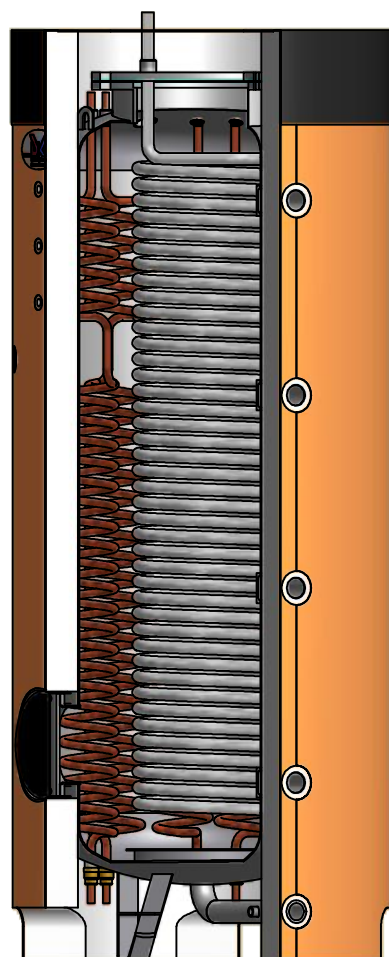

technical data

height of storage tank	2382mm
ø without insulation	800mm
ø with PVC-covering	1.000mm / 100mm non woven incl. polystyrolplate with completely glued PVC-covering
nominal content	1.000ltr.
weight whitout the heat exchangers	ca. 300kg
operating pressure	3bar
necessary flange for mounting the stainless steel spiral tube heat exchanger	DN500
maximum number of heat exchanger to be assembled	5 Stck.
stainless steel spiral tube heat exchanger dimension / length / weight	1" / 50mtr. / 18kg